

**KERGER TOOLS**  
Werkzeugtechnik



**Swiss Made**



**VHM-  
Schافتfräser**

# VHM - Schaftfräser Z=1 KT 20100

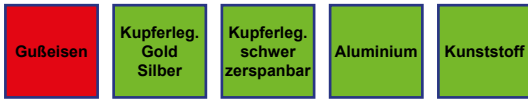

D <sub>1</sub> +0,005/-0,010	L <sub>1</sub>	D <sub>h4</sub>	L
0,20	0,40	3,00	39,00
0,30	0,60	3,00	39,00
0,40	0,80	3,00	39,00
0,50	1,00	3,00	39,00
0,60	1,20	3,00	39,00
0,70	1,40	3,00	39,00
0,80	1,60	3,00	39,00
0,90	1,80	3,00	39,00
1,00	2,00	3,00	39,00
1,10	2,20	3,00	39,00
1,20	2,40	3,00	39,00
1,30	2,60	3,00	39,00
1,40	2,80	3,00	39,00

D <sub>1</sub> +0,005/-0,010	L <sub>1</sub>	D <sub>h4</sub>	L
1,50	3,00	3,00	39,00
1,60	3,20	3,00	39,00
1,70	3,40	3,00	39,00
1,80	3,60	3,00	39,00
1,90	3,80	3,00	39,00
2,00	4,00	3,00	39,00
2,50	5,00	3,00	39,00
3,00	6,00	4,00*	40,00

\*h6

# VHM - Schaftfräser Z=1 KT 20145-2

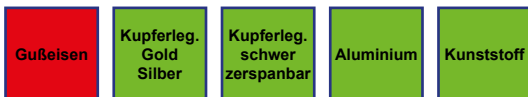

D <sub>1</sub> +0,005/-0,010	L <sub>1</sub>	D <sub>h4</sub>	L
0,20	0,40	3,00	39,00
0,30	0,60	3,00	39,00
0,40	0,80	3,00	39,00
0,50	1,00	3,00	39,00
0,60	1,20	3,00	39,00
0,70	1,40	3,00	39,00
0,80	1,60	3,00	39,00
0,90	1,80	3,00	39,00
1,00	2,00	3,00	39,00
1,10	2,20	3,00	39,00
1,20	2,40	3,00	39,00
1,30	2,60	3,00	39,00
1,40	2,80	3,00	39,00

D <sub>1</sub> +0,005/-0,010	L <sub>1</sub>	D <sub>h4</sub>	L
1,50	3,00	3,00	39,00
1,60	3,20	3,00	39,00
1,70	3,40	3,00	39,00
1,80	3,60	3,00	39,00
1,90	3,80	3,00	39,00
2,00	4,00	3,00	39,00
2,10	4,10	3,00	39,00
2,20	4,40	3,00	39,00
2,30	4,60	3,00	39,00
2,40	4,80	3,00	39,00
2,50	5,00	3,00	39,00
2,60	5,20	3,00	39,00
2,70	5,40	3,00	39,00
2,80	5,60	3,00	39,00
2,90	5,80	3,00	39,00
3,00	6,00	4,00*	40,00

\*h6

# VHM - Schaftfräser Z=1

## KT 20145-3



D <sub>1</sub> +0,005/-0,010	L <sub>1</sub>	D <sub>h4</sub>	L
0,30	0,90	3,00	39,00
0,40	1,20	3,00	39,00
0,50	1,50	3,00	39,00
0,60	1,80	3,00	39,00
0,70	2,10	3,00	39,00
0,80	2,40	3,00	39,00
0,90	2,70	3,00	39,00

D <sub>1</sub> +0,005/-0,010	L <sub>1</sub>	D <sub>h4</sub>	L
1,00	3,00	3,00	39,00
1,10	3,30	3,00	39,00
1,20	3,60	3,00	39,00
1,30	3,90	3,00	39,00
1,40	4,20	3,00	39,00
1,50	4,50	3,00	39,00
2,00	6,00	3,00	39,00
2,50	7,50	3,00	39,00
3,00	9,00	4,00*	40,00

\*h6

# VHM - Schaftfräser Z=1

## KT 20145-4

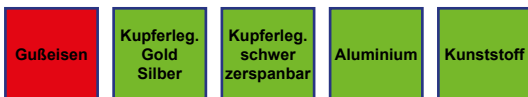

D <sub>1</sub> +0,005/-0,010	L <sub>1</sub>	D <sub>h4</sub>	L
0,30	1,20	3,00	39,00
0,40	1,60	3,00	39,00
0,50	2,00	3,00	39,00
0,60	2,40	3,00	39,00
0,70	2,80	3,00	39,00
0,80	3,20	3,00	39,00
0,90	3,60	3,00	39,00

D <sub>1</sub> +0,005/-0,010	L <sub>1</sub>	D <sub>h4</sub>	L
1,00	4,00	3,00	39,00
1,10	4,40	3,00	39,00
1,20	4,80	3,00	39,00
1,30	5,20	3,00	39,00
1,40	5,60	3,00	39,00
1,50	6,00	3,00	39,00
2,00	8,00	3,00	39,00
2,50	10,00	3,00	39,00
3,00	12,00	4,00*	40,00

\*h6

# VHM - Schaftfräser Z=2

mit verstärktem Schaft

## KT20230-0,75



Stahl  
+ Pb

niedrigleg.  
Stahl

hochleg.  
Stahl

rostfreier  
Stahl

Gußeisen

Titan  
Titanleg.

Kupferleg.  
Gold  
Silber

Aluminium

Kunststoff

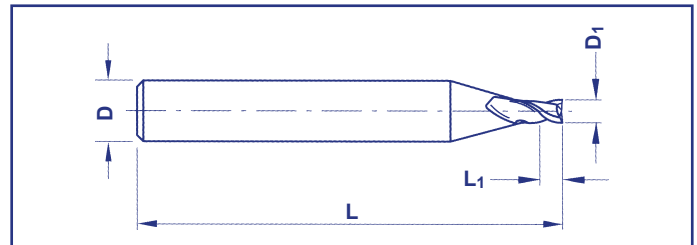

$D_1 +0,005/-0,010$	$L_1$	$D_{h4}$	L
0,20	0,15	3,00	39,00
0,30	0,25	3,00	39,00
0,40	0,30	3,00	39,00
0,50	0,37	3,00	39,00
0,60	0,45	3,00	39,00
0,70	0,53	3,00	39,00
0,80	0,60	3,00	39,00
0,90	0,70	3,00	39,00
1,00	0,75	3,00	39,00
1,10	0,90	3,00	39,00
1,20	0,90	3,00	39,00
1,30	1,00	3,00	39,00
1,40	1,10	3,00	39,00
1,50	1,15	3,00	39,00
1,60	1,20	3,00	39,00
1,70	1,30	3,00	39,00
1,80	1,40	3,00	39,00
1,90	1,45	3,00	39,00
2,00	1,50	3,00	39,00

# VHM - Schaftfräser Z=2

mit verstärktem Schaft

## KT20230-1



Stahl + Pb	niedrigleg. Stahl	hochleg. Stahl	rostfreier Stahl	Gußeisen
Titan Titanleg.	Kupferleg. Gold Silber	Aluminium	Kunststoff	

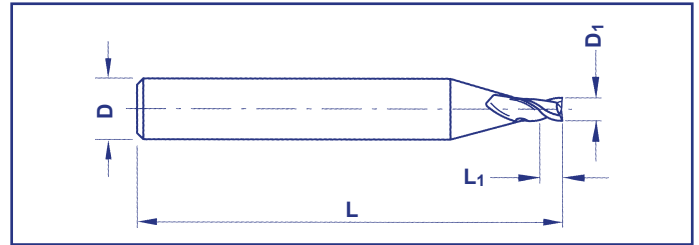

D <sub>1</sub> -0,010	L <sub>1</sub>	D <sub>h6</sub>	L
0,10	0,10	3,00	39,00
0,15	0,15	3,00	39,00
0,20	0,20	3,00	39,00
0,25	0,25	3,00	39,00
0,30	0,30	3,00	39,00
0,35	0,35	3,00	39,00
0,40	0,40	3,00	39,00
0,45	0,45	3,00	39,00
0,50	0,50	3,00	39,00
0,55	0,55	3,00	39,00
0,60	0,60	3,00	39,00
0,65	0,65	3,00	39,00
0,70	0,70	3,00	39,00
0,75	0,75	3,00	39,00
0,80	0,80	3,00	39,00
0,85	0,85	3,00	39,00
0,90	0,90	3,00	39,00
1,00	1,00	3,00	39,00
1,05	1,05	3,00	39,00
1,10	1,10	3,00	39,00
1,15	1,15	3,00	39,00
1,20	1,20	3,00	39,00
1,25	1,25	3,00	39,00
1,30	1,30	3,00	39,00
1,35	1,35	3,00	39,00
1,40	1,40	3,00	39,00
1,45	1,45	3,00	39,00
1,50	1,50	3,00	39,00
1,55	1,55	3,00	39,00
1,60	1,60	3,00	39,00
1,65	1,65	3,00	39,00
1,70	1,70	3,00	39,00
1,75	1,75	3,00	39,00
1,80	1,80	3,00	39,00
1,85	1,85	3,00	39,00
1,90	1,90	3,00	39,00
1,95	1,95	3,00	39,00

D <sub>1</sub> -0,020	L <sub>1</sub>	D <sub>h6</sub>	L
2,00	2,00	3,00	39,00
2,10	2,10	3,00	39,00
2,20	2,20	3,00	39,00
2,30	2,30	3,00	39,00
2,40	2,40	3,00	39,00
2,50	2,50	3,00	39,00

D <sub>1</sub> e8	L <sub>1</sub>	D <sub>h6</sub>	L
3,00	3,00	3,00	39,00
4,00	4,00	3,00	39,00
5,00	5,00	3,00	39,00

# VHM - Schaftfräser Z=2

mit verstärktem Schaft

## KT20230-1,5

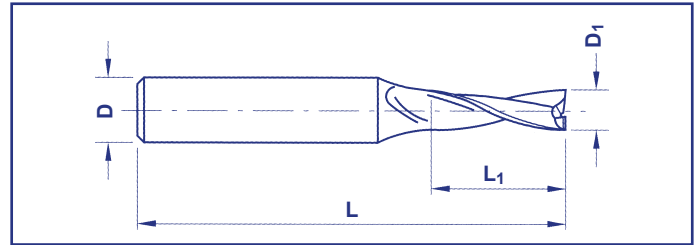

D <sub>1</sub> +0,005/-0,010	L <sub>1</sub>	D <sub>h4</sub>	L
0,10	0,15	3,00	39,00
0,15	0,20	3,00	39,00
0,20	0,30	3,00	39,00
0,25	0,35	3,00	39,00
0,30	0,45	3,00	39,00
0,40	0,60	3,00	39,00
0,50	0,75	3,00	39,00
0,60	0,90	3,00	39,00
0,70	1,05	3,00	39,00
0,80	1,20	3,00	39,00
0,90	1,35	3,00	39,00

D <sub>1</sub> +0,005/-0,010	L <sub>1</sub>	D <sub>h4</sub>	L
1,00	1,50	3,00	39,00
1,10	1,65	3,00	39,00
1,20	1,80	3,00	39,00
1,30	1,95	3,00	39,00
1,40	2,10	3,00	39,00
1,50	2,25	3,00	39,00
1,60	2,40	3,00	39,00
1,70	2,55	3,00	39,00
1,80	2,70	3,00	39,00
1,90	2,85	3,00	39,00
2,00	3,00	3,00	39,00

# VHM - Schaftfräser Z=2

mit verstärktem Schaft

## KT20230-2

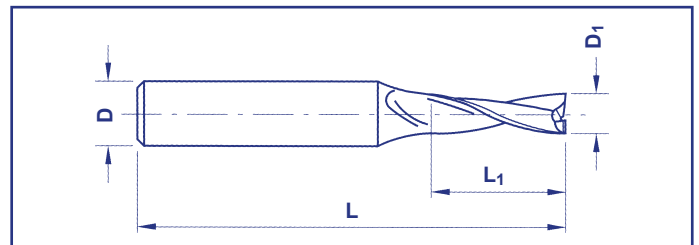

D <sub>1</sub> +0,005/-0,010	L <sub>1</sub>	D <sub>h4</sub>	L
0,10	0,20	3,00	39,00
0,15	0,30	3,00	39,00
0,20	0,40	3,00	39,00
0,25	0,50	3,00	39,00
0,30	0,60	3,00	39,00
0,40	0,80	3,00	39,00
0,50	1,00	3,00	39,00
0,60	1,20	3,00	39,00
0,70	1,40	3,00	39,00
0,80	1,60	3,00	39,00
0,90	1,80	3,00	39,00

D <sub>1</sub> +0,005/-0,010	L <sub>1</sub>	D <sub>h4</sub>	L
1,00	2,00	3,00	39,00
1,10	2,20	3,00	39,00
1,20	2,40	3,00	39,00
1,30	2,60	3,00	39,00
1,40	2,80	3,00	39,00
1,50	3,00	3,00	39,00
1,60	3,20	3,00	39,00
1,70	3,40	3,00	39,00
1,80	3,60	3,00	39,00
1,90	3,80	3,00	39,00
2,00	4,00	3,00	39,00

# VHM - Schaftfräser Z=2

## KT20230-3

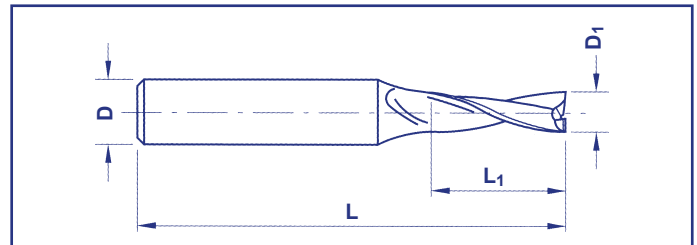

D1 +0,005/-0,010	L1	Dh4	L
0,10	0,25	3,00	39,00
0,15	0,45	3,00	39,00
0,20	0,50	3,00	39,00
0,25	0,75	3,00	39,00
0,30	1,00	3,00	39,00
0,35	1,10	3,00	39,00
0,40	1,20	3,00	39,00
0,50	1,50	3,00	39,00
0,60	2,00	3,00	39,00
0,65	2,00	3,00	39,00
0,70	2,00	3,00	39,00
0,75	2,00	3,00	39,00
0,80	2,50	3,00	39,00
0,90	2,50	3,00	39,00
0,95	3,00	3,00	39,00
1,00	3,00	3,00	39,00
1,05	3,00	3,00	39,00
1,10	3,00	3,00	39,00
1,15	3,50	3,00	39,00
1,20	4,00	3,00	39,00
1,30	4,00	3,00	39,00
1,35	4,00	3,00	39,00
1,40	4,00	3,00	39,00
1,45	4,40	3,00	39,00

D1 +0,005/-0,010	L1	Dh4	L
1,50	4,50	3,00	39,00
1,55	4,50	3,00	39,00
1,60	4,50	3,00	39,00
1,65	5,00	3,00	39,00
1,70	5,00	3,00	39,00
1,75	5,30	3,00	39,00
1,80	6,00	3,00	39,00
1,85	6,00	3,00	39,00
1,90	6,00	3,00	39,00
1,95	6,00	3,00	39,00
2,00	6,00	3,00	39,00
2,10	6,00	3,00	39,00
2,20	6,50	3,00	39,00
2,30	7,00	3,00	39,00
2,40	7,00	3,00	39,00
2,50	7,50	3,00	39,00
2,60	7,50	3,00	39,00
2,70	8,00	3,00	39,00
2,80	8,00	3,00	39,00
2,90	8,00	3,00	39,00

# VHM - Schaftfräser Z=2 KT20230-5

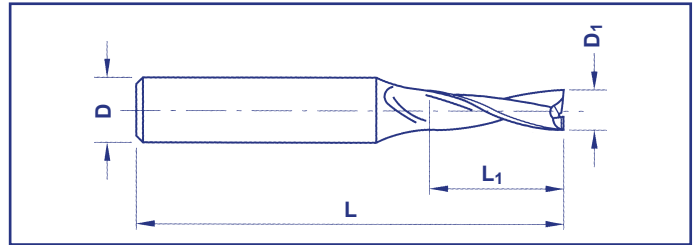

D <sub>1</sub> +0,005/-0,010	L <sub>1</sub>	D <sub>h4</sub>	L
0,30	1,50	3,00	39,00
0,35	1,80	3,00	39,00
0,40	2,00	3,00	39,00
0,50	2,50	3,00	39,00
0,55	2,80	3,00	39,00
0,60	3,00	3,00	39,00
0,65	3,30	3,00	39,00
0,70	3,50	3,00	39,00
0,75	3,80	3,00	39,00
0,80	4,00	3,00	39,00
0,85	4,30	3,00	39,00
0,90	4,50	3,00	39,00
0,95	4,80	3,00	39,00

D <sub>1</sub> +0,005/-0,010	L <sub>1</sub>	D <sub>h4</sub>	L
1,00	5,00	3,00	39,00
1,10	5,50	3,00	39,00
1,20	6,00	3,00	39,00
1,50	7,50	3,00	39,00
2,00	10,00	3,00	39,00
2,50	12,50	3,00	39,00

# VHM - Schaftfräser Z=2 KT20230-8

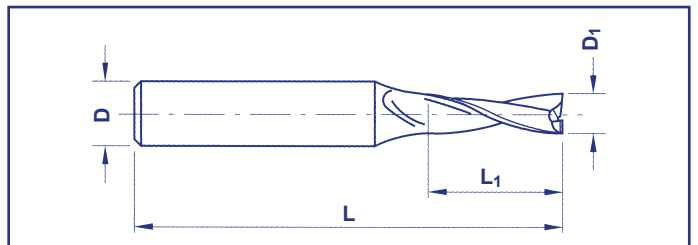

D <sub>1</sub> +0,005/-0,010	L <sub>1</sub>	D <sub>h4</sub>	L
0,40	3,20	3,00	39,00
0,50	4,00	3,00	39,00
0,60	5,00	3,00	39,00
0,70	5,60	3,00	39,00
0,80	6,00	3,00	39,00
0,90	7,20	3,00	39,00
1,00	8,00	3,00	39,00
1,20	9,00	3,00	39,00
1,50	12,00	4,00*	39,00
2,00	16,00	4,00*	39,00
2,50	20,00	4,00*	39,00



# VHM - Schaftfräser Z=2 KT21230-1

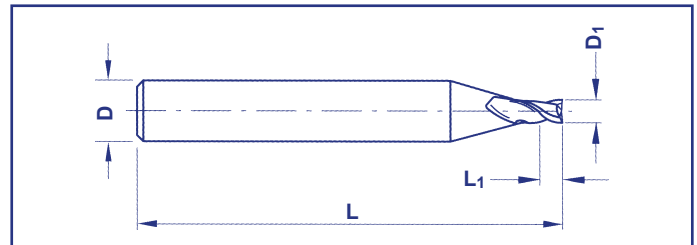

D <sub>1 h10</sub>	L <sub>1</sub>	D <sub>h6</sub>	L
1,00	1,00	6,00	50,00
1,50	1,50	6,00	50,00
2,00	2,00	6,00	50,00
2,50	2,50	6,00	50,00
3,00	3,00	6,00	50,00
4,00	4,00	6,00	50,00
5,00	5,00	6,00	50,00
6,00	6,00	6,00	50,00

# VHM - Schaftfräser Z=2 KT21230-3

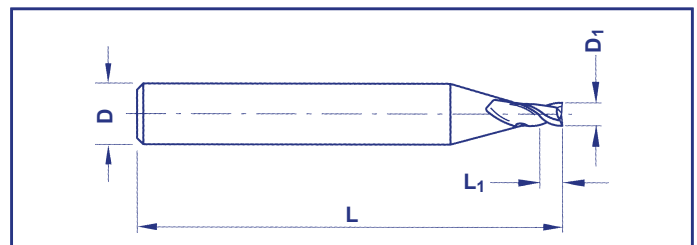

D <sub>1 h10</sub>	L <sub>1</sub>	D <sub>h6</sub>	L
2,00	8,00	2,00	32,00
2,50	8,00	2,50	32,00
3,00	12,00	3,00	32,00
3,50	12,00	3,50	32,00
4,00	12,00	4,00	40,00
4,50	14,00	4,50	50,00
5,00	14,00	5,00	50,00
6,00	16,00	6,00	50,00

# VHM - Schaftfräser Z=3

## KT20330-1,3



Stahl  
+ Pb

niedrigleg.  
Stahl

hochleg.  
Stahl

rostfreier  
Stahl

Gußeisen

Titan  
Titanleg.

Kupferleg.  
Gold  
Silber

Aluminium

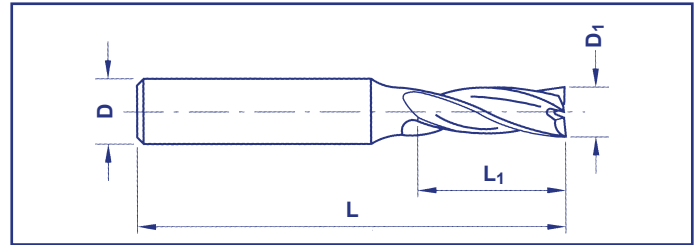

D1 +0,005/-0,010	L1	Dh4	L
0,30	0,40	3,00	39,00
0,40	0,50	3,00	39,00
0,45	0,60	3,00	39,00
0,50	0,70	3,00	39,00
0,60	0,80	3,00	39,00
0,70	0,90	3,00	39,00
0,80	1,00	3,00	39,00
0,90	1,30	3,00	39,00
1,00	1,30	3,00	39,00
1,10	1,50	3,00	39,00
1,20	1,60	3,00	39,00
1,30	1,80	3,00	39,00
1,40	1,80	3,00	39,00

D1 +0,005/-0,010	L1	Dh4	L
1,50	2,00	3,00	39,00
1,60	2,00	3,00	39,00
1,70	2,00	3,00	39,00
1,80	2,40	3,00	39,00
1,90	2,40	3,00	39,00
2,00	2,60	3,00	39,00
2,20	3,00	3,00	39,00
2,50	3,30	3,00	39,00
2,80	3,50	3,00	39,00
2,90	3,50	3,00	39,00

# VHM - Schaftfräser Z=3 KT20330-2

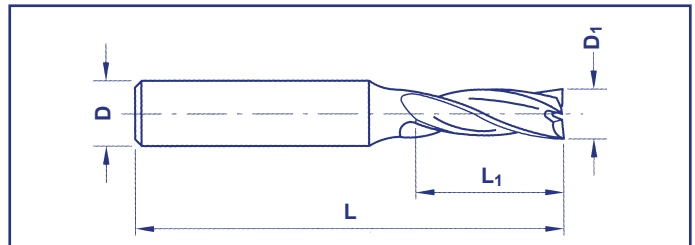

D1 +0,005/-0,010	L1	Dh4	L
0,30	0,60	3,00	39,00
0,40	0,80	3,00	39,00
0,50	1,00	3,00	39,00
0,60	1,20	3,00	39,00
0,70	1,40	3,00	39,00
0,75	1,50	3,00	39,00
0,80	1,60	3,00	39,00
0,90	1,80	3,00	39,00
1,00	2,00	3,00	39,00
1,10	2,20	3,00	39,00
1,20	2,40	3,00	39,00
1,30	2,60	3,00	39,00
1,40	2,80	3,00	39,00

D1 +0,005/-0,010	L1	Dh4	L
1,50	3,00	3,00	39,00
1,60	3,20	3,00	39,00
1,70	3,40	3,00	39,00
1,80	3,60	3,00	39,00
1,90	3,80	3,00	39,00
2,00	4,00	3,00	39,00
2,10	4,20	3,00	39,00
2,20	4,40	3,00	39,00
2,30	4,60	3,00	39,00
2,40	4,80	3,00	39,00
2,50	5,00	3,00	39,00
2,60	5,20	3,00	39,00
2,70	5,40	3,00	39,00
2,80	5,60	3,00	39,00
2,90	5,80	3,00	39,00

# VHM - Schaftfräser Z=3 KT20330-3

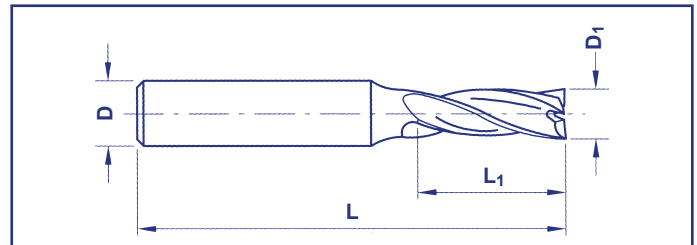

D1 +0,005/-0,010	L1	Dh4	L
0,30	0,90	3,00	39,00
0,40	1,20	3,00	39,00
0,50	1,50	3,00	39,00
0,60	2,00	3,00	39,00
0,70	2,00	3,00	39,00
0,75	2,00	3,00	39,00
0,80	2,50	3,00	39,00
0,90	2,50	3,00	39,00
1,00	3,00	3,00	39,00
1,10	3,30	3,00	39,00
1,20	4,00	3,00	39,00
1,30	4,00	3,00	39,00
1,40	4,00	3,00	39,00

D1 +0,005/-0,010	L1	Dh4	L
1,50	4,50	3,00	39,00
1,60	4,50	3,00	39,00
1,70	5,00	3,00	39,00
1,80	6,00	3,00	39,00
1,90	6,00	3,00	39,00
2,00	6,00	3,00	39,00
2,10	6,00	3,00	39,00
2,20	6,50	3,00	39,00
2,30	7,00	3,00	39,00
2,40	7,00	3,00	39,00
2,50	7,50	3,00	39,00
2,60	7,50	3,00	39,00
2,70	8,00	3,00	39,00
2,80	8,00	3,00	39,00
2,90	8,50	3,00	39,00

# VHM - Schaftfräser Z=3 KT20330-4

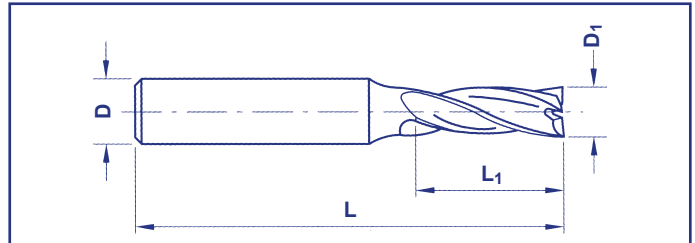

D1 +0,005/-0,010	L1	Dh4	L
0,30	1,20	3,00	39,00
0,40	1,60	3,00	39,00
0,50	2,00	3,00	39,00
0,60	2,40	3,00	39,00
0,70	2,80	3,00	39,00
0,75	3,00	3,00	39,00
0,80	3,20	3,00	39,00
0,90	3,60	3,00	39,00
1,00	4,00	3,00	39,00
1,10	4,40	3,00	39,00
1,20	4,80	3,00	39,00
1,30	5,20	3,00	39,00
1,40	5,60	3,00	39,00

D1 +0,005/-0,010	L1	Dh4	L
1,50	6,00	3,00	39,00
1,60	6,40	3,00	39,00
1,70	6,80	3,00	39,00
1,80	7,20	3,00	39,00
1,90	7,60	3,00	39,00
2,00	8,00	3,00	39,00
2,10	8,40	3,00	39,00
2,20	8,80	3,00	39,00
2,30	9,20	3,00	39,00
2,40	9,60	3,00	39,00
2,50	10,00	3,00	39,00
2,60	10,40	3,00	39,00
2,70	10,80	3,00	39,00
2,80	11,20	3,00	39,00
2,90	11,60	3,00	39,00

# VHM - Schaftfräser Z=3 KT20330-5



D <sub>1</sub> +0,005/-0,010	L <sub>1</sub>	D <sub>h4</sub>	L
0,50	2,50	3,00	39,00
0,60	3,00	3,00	39,00
0,70	3,50	3,00	39,00
0,80	4,00	3,00	39,00
0,90	4,50	3,00	39,00

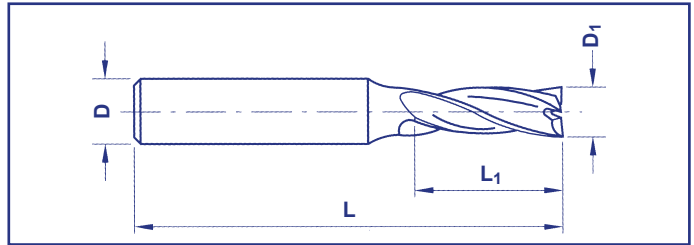

D <sub>1</sub> +0,005/-0,010	L <sub>1</sub>	D <sub>h4</sub>	L
1,00	5,00	3,00	39,00
1,10	5,50	3,00	39,00
1,20	6,00	3,00	39,00
1,50	7,50	3,00	39,00
2,00	10,00	3,00	39,00
2,50	12,50	3,00	39,00

# VHM - Schaftfräser Z=3 KT20330-8



D <sub>1</sub> +0,005/-0,010	L <sub>1</sub>	D <sub>h4</sub>	L
0,50	4,00	3,00	39,00
0,60	5,00	3,00	39,00
0,70	5,60	3,00	39,00
0,80	6,00	3,00	39,00
0,90	7,20	3,00	39,00

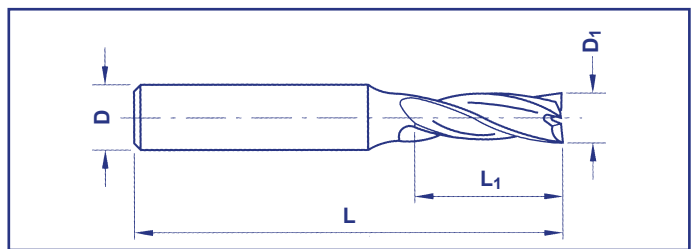

D <sub>1</sub> +0,005/-0,010	L <sub>1</sub>	D <sub>h4</sub>	L
1,00	8,00	3,00	39,00
1,20	9,00	3,00	39,00
1,50	12,00	4,00*	39,00
2,00	16,00	4,00*	39,00
2,50	20,00	4,00*	39,00

\*h6

# VHM - Schaftfräser Z=3 KT21330-1

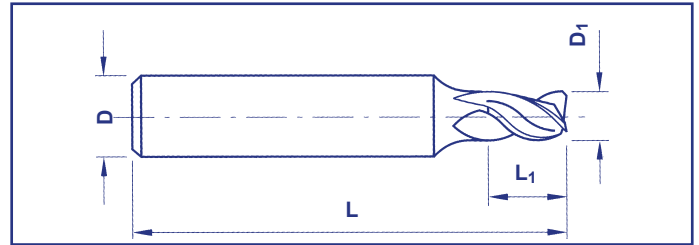

D <sub>1 e9</sub>	L <sub>1</sub>	D <sub>h6</sub>	L
3,00	3,00	3,00	39,00
4,00	4,00	4,00	50,00
5,00	5,00	5,00	50,00
6,00	6,00	6,00	50,00
8,00	8,00	8,00	58,00
10,00	10,00	10,00	66,00
12,00	12,00	12,00	73,00

# VHM - Schaftfräser Z=3 KT21330-1,2

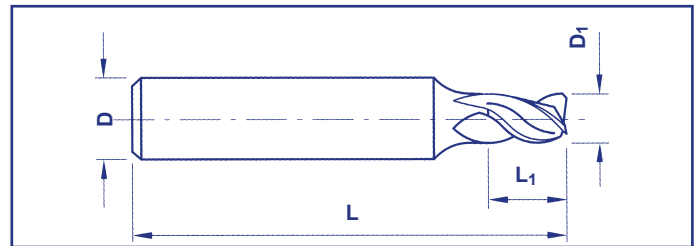

D <sub>1 h10</sub>	L <sub>1</sub>	D <sub>h6</sub>	L
1,50	3,00	6,00	50,00
1,80	3,00	6,00	50,00
2,00	3,00	6,00	50,00
2,50	3,00	6,00	50,00
2,80	4,00	6,00	50,00
3,00	4,00	6,00	50,00
3,50	4,00	6,00	50,00
3,80	5,00	6,00	54,00

D <sub>1 h10</sub>	L <sub>1</sub>	D <sub>h6</sub>	L
4,00	5,00	6,00	54,00
4,50	5,00	6,00	54,00
4,80	6,00	6,00	54,00
5,00	6,00	6,00	54,00
5,50	7,00	6,00	54,00
5,80	7,00	6,00	54,00
6,00	7,00	6,00	54,00

# VHM - Schaftfräser Z=3

mit verstärktem Schaft

## KT21330-2



D <sub>1</sub> h10	L <sub>1</sub>	D <sub>h6</sub>	L
1,00	3,00	6,00	40,00
1,50	3,00	6,00	40,00
2,00	3,00	6,00	40,00
2,50	3,00	6,00	40,00
3,00	4,00	6,00	40,00
3,50	4,00	6,00	40,00
4,00	5,00	6,00	40,00
4,50	5,00	6,00	40,00
5,00	6,00	6,00	40,00
6,00	7,00	6,00	40,00

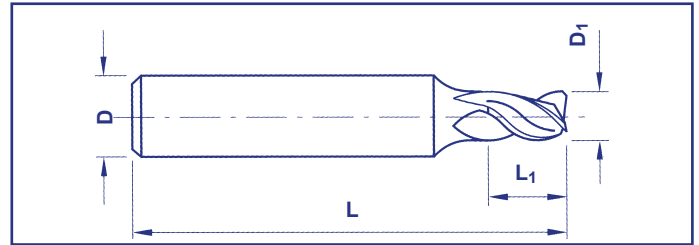

# VHM - Schaftfräser Z=3

## KT21330-3



D <sub>1</sub> h10	L <sub>1</sub>	D <sub>h6</sub>	L
1,50	6,00	6,00	57,00
1,80	6,00	6,00	57,00
2,00	6,00	6,00	57,00
2,50	6,00	6,00	57,00
2,80	7,00	6,00	57,00
3,00	7,00	6,00	57,00
3,50	7,00	6,00	57,00
3,80	8,00	6,00	57,00

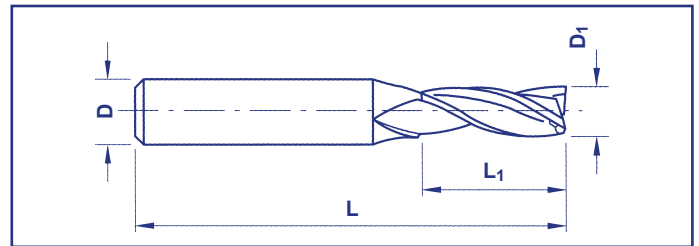

D <sub>1</sub> h10	L <sub>1</sub>	D <sub>h6</sub>	L
4,00	8,00	6,00	57,00
4,50	8,00	6,00	57,00
4,80	10,00	6,00	57,00
5,00	10,00	6,00	57,00
5,50	10,00	6,00	57,00
5,80	10,00	6,00	57,00
6,00	10,00	6,00	57,00



# VHM - Schaftfräser Z=3 KT21330-3,5



D <sub>1</sub> e9	L <sub>1</sub>	D <sub>h6</sub>	L
2,00	8,00	2,00	32,00
2,50	8,00	2,50	32,00
3,00	12,00	3,00	32,00
3,50	12,00	3,50	32,00
4,00	12,00	4,00	40,00
4,50	14,00	4,50	50,00
5,00	14,00	5,00	50,00
6,00	16,00	6,00	50,00

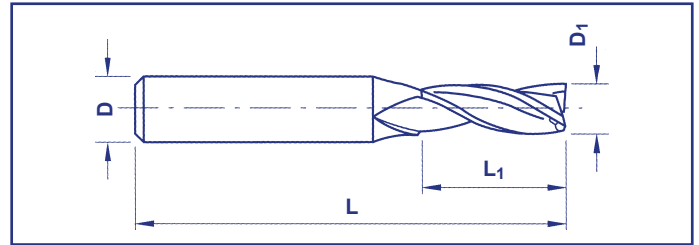

# VHM - Schaftfräser Z=3 KT20345-2,5



D <sub>1</sub> +0,005/-0,010	L <sub>1</sub>	D <sub>h4</sub>	L
0,30	0,80	3,00	39,00
0,40	1,00	3,00	39,00
0,50	1,30	3,00	39,00
0,60	1,50	3,00	39,00
0,70	1,70	3,00	39,00
0,80	2,00	3,00	39,00
0,90	2,30	3,00	39,00
1,00	2,50	3,00	39,00
1,10	2,80	3,00	39,00
1,20	3,00	3,00	39,00
1,30	3,30	3,00	39,00
1,40	3,50	3,00	39,00

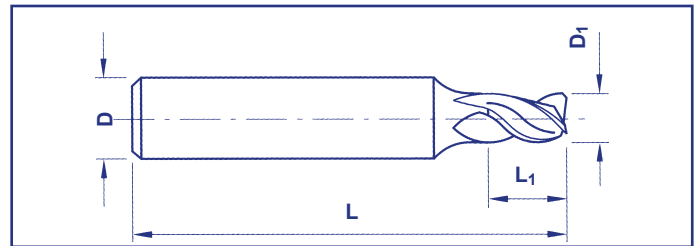

D <sub>1</sub> +0,005/-0,010	L <sub>1</sub>	D <sub>h4</sub>	L
1,50	3,80	3,00	39,00
1,60	4,00	3,00	39,00
1,70	4,30	3,00	39,00
1,80	4,50	3,00	39,00
1,90	4,80	3,00	39,00
2,00	5,00	3,00	39,00
2,10	5,30	3,00	39,00
2,20	5,50	3,00	39,00
2,30	5,80	3,00	39,00
2,40	6,00	3,00	39,00
2,50	6,30	3,00	39,00
2,60	6,50	3,00	39,00
2,70	6,80	3,00	39,00
2,80	7,00	3,00	39,00
2,90	7,30	3,00	39,00

# VHM - Schaftfräser Z=3

## KT21345-4

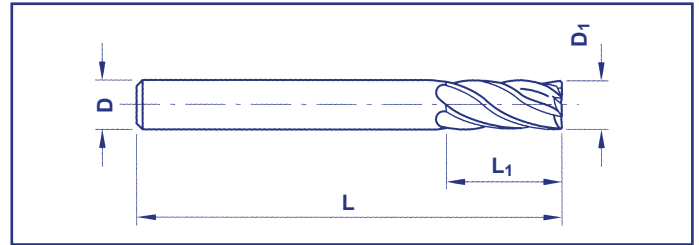

D <sub>1 e9</sub>	L <sub>1</sub>	D <sub>h6</sub>	L
2,00	8,00	2,00	32,00
2,50	8,00	2,50	32,00
3,00	12,00	3,00	32,00
3,50	12,00	3,50	32,00
4,00	12,00	4,00	40,00
4,50	14,00	4,50	50,00
5,00	14,00	5,00	50,00
6,00	16,00	6,00	50,00

# VHM - Schaftfräser Z=3

## ungleiche Teilung, variabler Drallwinkel

### KT20336-1,5

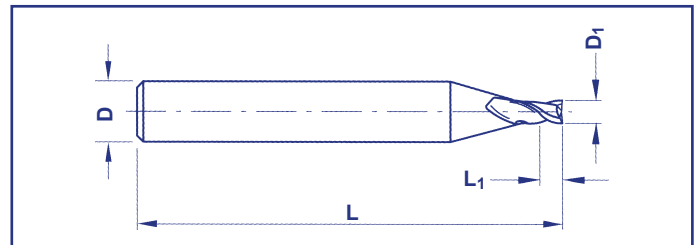
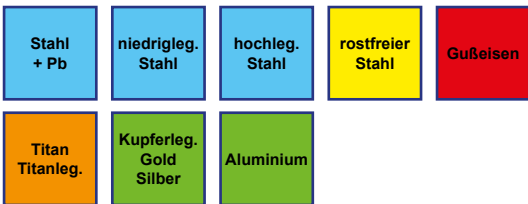

D <sub>1 +0,005/-0,010</sub>	L <sub>1</sub>	D <sub>h4</sub>	L
0,30	0,45	3,00	39,00
0,40	0,60	3,00	39,00
0,50	0,75	3,00	39,00
0,60	0,90	3,00	39,00
0,70	1,05	3,00	39,00
0,80	1,20	3,00	39,00
0,90	1,35	3,00	39,00
1,00	1,50	3,00	39,00
1,10	1,65	3,00	39,00
1,20	1,80	3,00	39,00
1,30	1,95	3,00	39,00
1,40	2,10	3,00	39,00

D <sub>1 +0,005/-0,010</sub>	L <sub>1</sub>	D <sub>h4</sub>	L
1,50	2,25	3,00	39,00
1,60	2,40	3,00	39,00
1,70	2,55	3,00	39,00
1,80	2,70	3,00	39,00
1,90	2,85	3,00	39,00
2,00	3,00	3,00	39,00
2,50	3,75	3,00	39,00

# VHM - Schaftfräser Z=3

ungleiche Teilung, variabler Drallwinkel

## KT20336-3

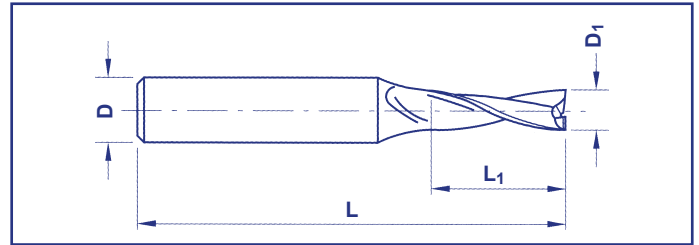

D <sub>1</sub> +0,005/-0,010	L <sub>1</sub>	D <sub>h4</sub>	L
0,30	0,90	3,00	39,00
0,40	1,20	3,00	39,00
0,50	1,50	3,00	39,00
0,60	1,80	3,00	39,00
0,70	2,10	3,00	39,00
0,80	2,40	3,00	39,00
0,90	2,70	3,00	39,00
1,00	3,00	3,00	39,00
1,10	3,30	3,00	39,00
1,20	3,60	3,00	39,00
1,30	3,90	3,00	39,00
1,40	4,20	3,00	39,00

D <sub>1</sub> +0,005/-0,010	L <sub>1</sub>	D <sub>h4</sub>	L
1,50	4,50	3,00	39,00
1,60	4,80	3,00	39,00
1,70	5,10	3,00	39,00
1,80	5,40	3,00	39,00
1,90	5,70	3,00	39,00
2,00	6,00	3,00	39,00
2,50	7,50	3,00	39,00

# VHM - Schaftfräser Z=3

ungleiche Teilung, variabler Drallwinkel

## KT21335-4

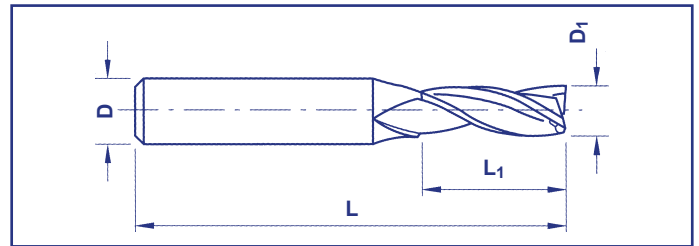

D <sub>1</sub> h10	L <sub>1</sub>	D <sub>h6</sub>	L
1,00	4,00	6,00	40,00
1,50	4,00	6,00	40,00
2,00	4,00	6,00	40,00
2,50	4,00	6,00	40,00
3,00	5,00	6,00	40,00
3,50	5,00	6,00	40,00
4,00	6,00	6,00	40,00
5,00	7,00	6,00	40,00
6,00	8,00	6,00	40,00

# VHM - Schaftfräser Z=3 KT21360



Stahl  
+ Pb

niedrigleg.  
Stahl

hochleg.  
Stahl

rostfreier  
Stahl

Gußeisen

Titan  
Titanleg.

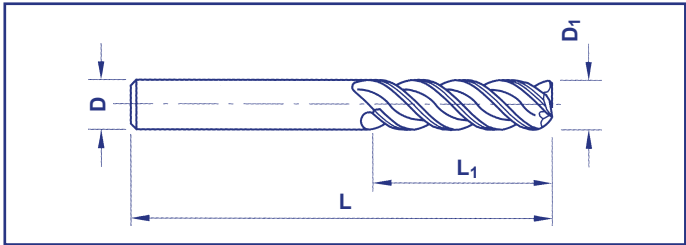

$D_{1\text{e9}}$	$L_1$	$D_{\text{h6}}$	L
2,00	8,00	2,00	32,00
2,50	8,00	2,50	32,00
3,00	12,00	3,00	32,00
3,50	12,00	3,50	32,00
4,00	12,00	4,00	40,00
4,50	14,00	4,50	50,00
5,00	14,00	5,00	50,00
6,00	16,00	6,00	50,00

# VHM - Schaftfräser Z=4 KT21430-1



Stahl + Pb	niedrigleg. Stahl	hochleg. Stahl	rostfreier Stahl	Gußeisen	Titan Titanleg.
Kupferleg. Gold Silber	Kupferleg. schwer zerspanbar	Aluminium	Kunststoff		

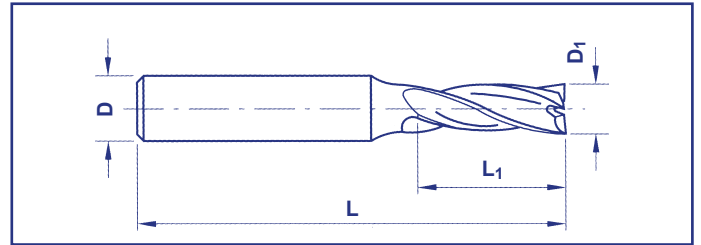

D <sub>1</sub> e9	L <sub>1</sub>	D <sub>h6</sub>	L
3,00	3,00	3,00	39,00
4,00	4,00	4,00	50,00
5,00	5,00	5,00	50,00
6,00	6,00	6,00	50,00

# VHM - Schaftfräser Z=4 KT21430-4



Stahl + Pb	niedrigleg. Stahl	hochleg. Stahl	rostfreier Stahl	Gußeisen	Titan Titanleg.
Kupferleg. Gold Silber	Kupferleg. schwer zerspanbar	Aluminium	Kunststoff		

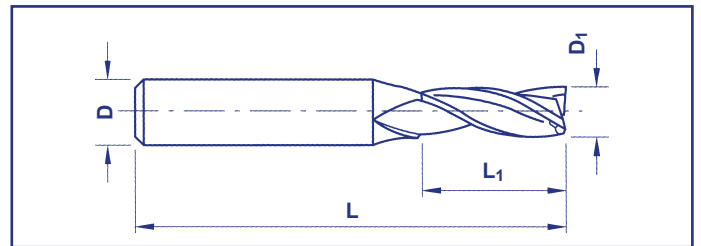

D <sub>1</sub> e9	L <sub>1</sub>	D <sub>h6</sub>	L
2,00	8,00	2,00	32,00
2,50	8,00	2,50	32,00
3,00	12,00	3,00	32,00
3,50	12,00	3,50	32,00
4,00	12,00	4,00	40,00
4,50	14,00	4,50	50,00
5,00	14,00	5,00	50,00
6,00	16,00	6,00	50,00

# VHM - Schaftfräser Z=4

## KT20430-1,5



Stahl + Pb	niedrigleg. Stahl	hochleg. Stahl	rostfreier Stahl	Gußeisen	Titan Titanleg.
Kupferleg. Gold Silber	Kupferleg. schwer zerspanbar	Aluminium	Kunststoff	Graphit	

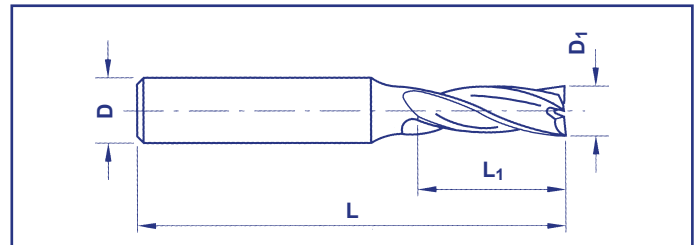

D1 +0,005/-0,010	L1	Dh4	L
0,30	0,45	3,00	39,00
0,40	0,60	3,00	39,00
0,50	0,75	3,00	39,00
0,60	0,90	3,00	39,00
0,70	1,05	3,00	39,00
0,80	1,20	3,00	39,00
0,90	1,35	3,00	39,00
1,00	1,50	3,00	39,00
1,10	1,65	3,00	39,00
1,20	1,80	3,00	39,00
1,30	1,95	3,00	39,00
1,40	2,10	3,00	39,00
1,50	2,25	3,00	39,00
1,60	2,40	3,00	39,00
1,70	2,55	3,00	39,00
1,80	2,70	3,00	39,00
1,90	2,85	3,00	39,00

D1 +0,005/-0,010	L1	Dh4	L
2,00	3,00	3,00	39,00
2,10	3,15	3,00	39,00
2,20	3,30	3,00	39,00
2,30	3,45	3,00	39,00
2,40	3,60	3,00	39,00
2,50	3,75	3,00	39,00
2,60	3,90	3,00	39,00
2,70	4,05	3,00	39,00
2,80	4,20	3,00	39,00
2,90	4,35	3,00	39,00

# VHM - Schaftfräser Z=4 KT20430-3



Stahl  
+ Pb

niedrigleg.  
Stahl

hochleg.  
Stahl

rostfreier  
Stahl

Gußeisen

Titan  
Titanleg.

Kupferleg.  
Gold  
Silber

Kupferleg.  
schwer  
zerspanbar

Aluminium

Kunststoff

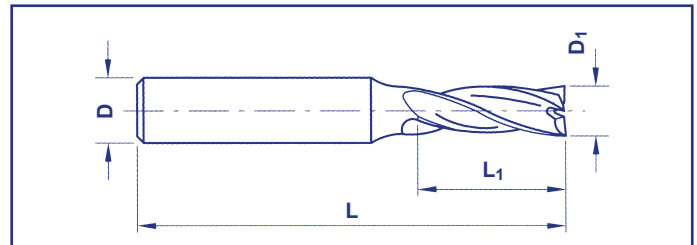

D1 +0,005/-0,010	L1	Dh6	L
0,30	0,90	3,00	39,00
0,40	1,20	3,00	39,00
0,50	1,50	3,00	39,00
0,60	1,80	3,00	39,00
0,70	2,10	3,00	39,00
0,80	2,40	3,00	39,00
0,90	2,70	3,00	39,00
1,00	3,00	3,00	39,00
1,10	3,30	3,00	39,00
1,20	3,60	3,00	39,00
1,30	3,90	3,00	39,00
1,40	4,20	3,00	39,00

D1 +0,005/-0,010	L1	Dh6	L
1,50	4,50	3,00	39,00
1,60	4,80	3,00	39,00
1,70	5,10	3,00	39,00
1,80	5,40	3,00	39,00
1,90	5,70	3,00	39,00
2,00	6,00	3,00	39,00
2,10	6,30	3,00	39,00
2,20	6,60	3,00	39,00
2,30	6,90	3,00	39,00
2,40	7,20	3,00	39,00
2,50	7,50	3,00	39,00
2,60	7,80	3,00	39,00
2,70	8,10	3,00	39,00
2,80	8,40	3,00	39,00
2,90	8,70	3,00	39,00

# VHM - Schaftfräser Z=4 KT20440-2



Stahl  
+ Pb

niedrigleg.  
Stahl

hochleg.  
Stahl

rostfreier  
Stahl

Gußeisen

Titan  
Titanleg.

Kupferleg.  
Gold  
Silber

Kupferleg.  
schwer  
zerspanbar

Aluminium

Kunststoff

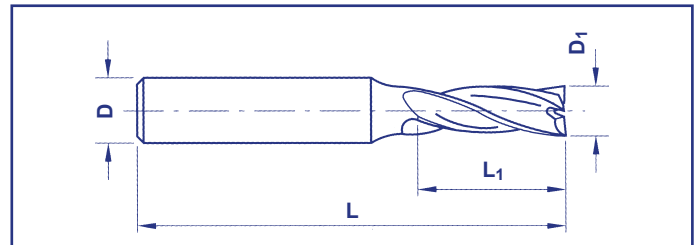

D <sub>1</sub> +0,005/-0,010	L <sub>1</sub>	D <sub>h6</sub>	L
0,30	0,60	3,00	39,00
0,40	0,80	3,00	39,00
0,50	1,00	3,00	39,00
0,60	1,20	3,00	39,00
0,70	1,40	3,00	39,00
0,80	1,60	3,00	39,00
0,90	1,80	3,00	39,00
1,00	2,00	3,00	39,00
1,10	2,20	3,00	39,00
1,20	2,40	3,00	39,00
1,30	2,60	3,00	39,00
1,40	2,80	3,00	39,00

D <sub>1</sub> +0,005/-0,010	L <sub>1</sub>	D <sub>h6</sub>	L
1,50	3,00	3,00	39,00
1,60	3,20	3,00	39,00
1,70	3,40	3,00	39,00
1,80	3,60	3,00	39,00
1,90	3,80	3,00	39,00
2,00	4,00	3,00	39,00
2,10	4,20	3,00	39,00
2,20	4,40	3,00	39,00
2,30	4,60	3,00	39,00
2,40	4,80	3,00	39,00
2,50	5,00	3,00	39,00
2,60	5,20	3,00	39,00
2,70	5,40	3,00	39,00
2,80	5,60	3,00	39,00
2,90	5,80	3,00	39,00



# VHM - Schaftfräser Z=4

## KT20440-4



Stahl  
+ Pb

niedrigleg.  
Stahl

hochleg.  
Stahl

rostfreier  
Stahl

Gußeisen

Titan  
Titanleg.

Kupferleg.  
Gold  
Silber

Kupferleg.  
schwer  
zerspanbar

Aluminium

Kunststoff

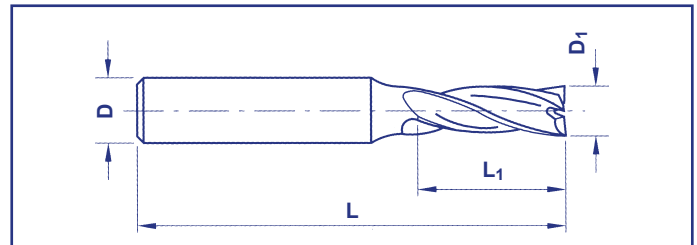

D1 +0,005/-0,010	L1	Dh6	L
0,40	1,60	3,00	39,00
0,50	2,00	3,00	39,00
0,60	2,40	3,00	39,00
0,70	2,80	3,00	39,00
0,80	3,20	3,00	39,00
0,90	3,60	3,00	39,00
1,00	4,00	3,00	39,00
1,10	4,40	3,00	39,00
1,20	4,80	3,00	39,00
1,30	5,20	3,00	39,00
1,40	5,60	3,00	39,00

D1 +0,005/-0,010	L1	Dh6	L
1,50	6,00	3,00	39,00
1,60	6,40	3,00	39,00
1,70	6,80	3,00	39,00
1,80	7,20	3,00	39,00
1,90	7,60	3,00	39,00
2,00	8,00	3,00	39,00
2,10	8,40	3,00	39,00
2,20	8,80	3,00	39,00
2,30	9,20	3,00	39,00
2,40	9,60	3,00	39,00
2,50	10,00	3,00	39,00
2,60	10,40	3,00	39,00
2,70	10,80	3,00	39,00
2,80	11,20	3,00	39,00
2,90	11,60	3,00	39,00

# VHM - Schaftfräser Z=4 KT21445-2



Stahl + Pb	niedrigleg. Stahl	hochleg. Stahl	rostfreier Stahl	Gußeisen	Titan Titanleg.
Kupferleg. Gold Silber	Kupferleg. schwer zerspanbar	Aluminium			

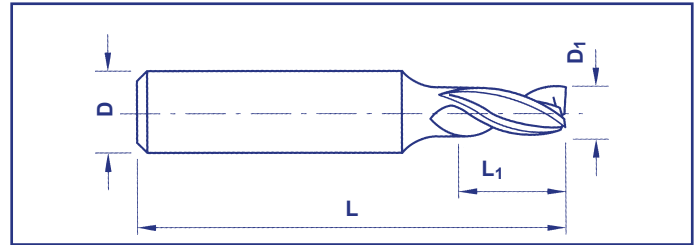

D <sub>1</sub> h10	L <sub>1</sub>	D <sub>h6</sub>	L
1,00	2,00	6,00	40,00
1,50	3,00	6,00	40,00
2,00	4,00	6,00	40,00
2,50	5,00	6,00	40,00
3,00	6,00	6,00	40,00
3,50	7,00	6,00	40,00
4,00	8,00	6,00	40,00
4,50	9,00	6,00	40,00

D <sub>1</sub> h10	L <sub>1</sub>	D <sub>h6</sub>	L
5,00	10,00	6,00	40,00
5,50	11,00	6,00	40,00
6,00	12,00	6,00	40,00

# VHM - Schaftfräser Z=4 KT21445-4



Stahl + Pb	niedrigleg. Stahl	hochleg. Stahl	rostfreier Stahl	Gußeisen	Titan Titanleg.
Kupferleg. Gold Silber	Kupferleg. schwer zerspanbar	Aluminium			

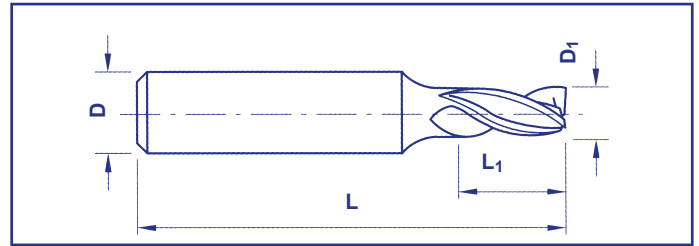

D <sub>1</sub> e9	L <sub>1</sub>	D <sub>h6</sub>	L
2,00	8,00	2,00	32,00
2,50	8,00	2,50	32,00
3,00	12,00	3,00	32,00
3,50	12,00	3,50	32,00

D <sub>1</sub> e9	L <sub>1</sub>	D <sub>h6</sub>	L
4,00	12,00	4,00	40,00
4,50	14,00	4,50	50,00
5,00	14,00	5,00	50,00
6,00	16,00	6,00	50,00

# VHM - Schaftfräser Z=4

## KT20435-3

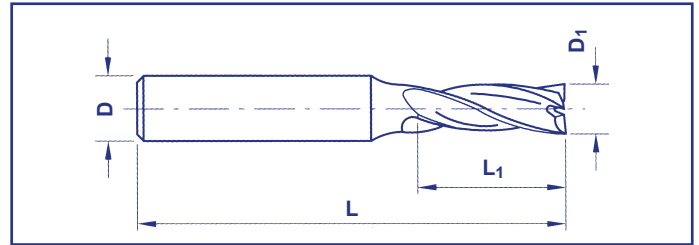

D <sub>1</sub> +0,005/-0,010	L <sub>1</sub>	D <sub>h6</sub>	L
0,50	1,50	3,00	39,00
0,60	1,80	3,00	39,00
0,70	2,10	3,00	39,00
0,80	2,40	3,00	39,00
0,90	2,70	3,00	39,00
1,00	3,00	3,00	39,00
1,10	3,30	3,00	39,00
1,20	3,60	3,00	39,00
1,30	3,90	3,00	39,00
1,40	4,20	3,00	39,00

D <sub>1</sub> +0,005/-0,010	L <sub>1</sub>	D <sub>h6</sub>	L
1,50	4,50	3,00	39,00
1,60	4,80	3,00	39,00
1,70	5,10	3,00	39,00
1,80	5,40	3,00	39,00
1,90	5,70	3,00	39,00
2,00	6,00	3,00	39,00
2,50	7,50	3,00	39,00

# VHM - Schaftfräser Z=4

## ungleiche Teilung, variabler Drallwinkel

## KT21435

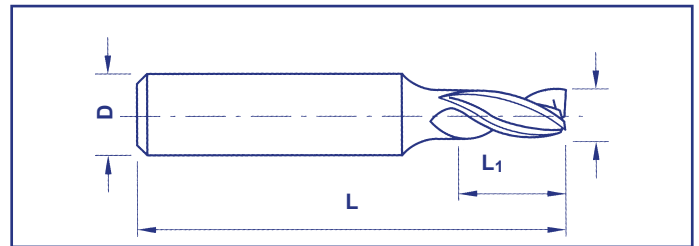

D <sub>1</sub> e9	L <sub>1</sub>	D <sub>h6</sub>	L
1,00	4,00	6,00	40,00
1,50	4,00	6,00	40,00
2,00	4,00	6,00	40,00
2,50	4,00	6,00	40,00

D <sub>1</sub> e9	L <sub>1</sub>	D <sub>h6</sub>	L
3,00	5,00	6,00	40,00
3,50	5,00	6,00	40,00
4,00	6,00	6,00	40,00
5,00	7,00	6,00	40,00
6,00	8,00	6,00	40,00

# VHM - Schruppfräser Z=3 KT24326-1,5



Stahl + Pb	niedrigleg. Stahl	Gußeisen			
Gold Silber	Kupferleg. schwer zerspanbar	Aluminium	Aluminium < 8% Si	Aluminium > 8% Si	Kunststoff

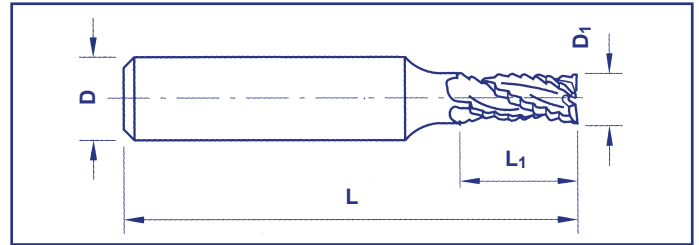

D <sub>1</sub> d10	L <sub>1</sub>	D <sub>h6</sub>	L	Z
1,00	1,50	3,00	39,00	3
1,50	2,25	3,00	39,00	3
2,00	3,00	3,00	39,00	3
2,50	3,75	6,00	51,00	3
3,00	4,50	6,00	51,00	3
4,00	6,00	6,00	51,00	3
5,00	7,50	6,00	51,00	3
6,00	9,00	6,00	51,00	3
8,00	12,00	8,00	64,00	3
10,00	15,00	10,00	73,00	4

# VHM - Schruppfräser Z=3 KT24326-2,5



Stahl + Pb	niedrigleg. Stahl	Gußeisen			
Gold Silber	Kupferleg. schwer zerspanbar	Aluminium	Aluminium < 8% Si	Aluminium > 8% Si	Kunststoff

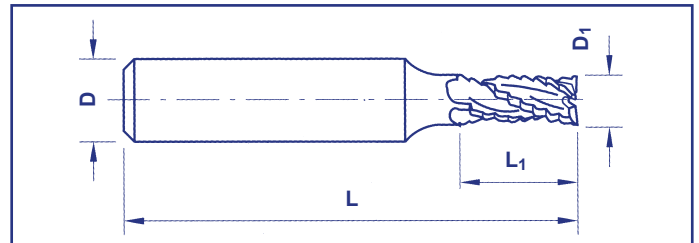

D <sub>1</sub> d10	L <sub>1</sub>	D <sub>h6</sub>	L	Z
1,00	2,50	3,00	39,00	3
1,50	3,75	3,00	39,00	3
2,00	5,00	3,00	39,00	3
2,50	6,25	6,00	58,00	3
3,00	7,50	6,00	58,00	3
4,00	10,00	6,00	58,00	3
5,00	12,50	6,00	58,00	3
6,00	15,00	6,00	58,00	3
8,00	20,00	8,00	64,00	3
10,00	25,00	10,00	73,00	4

# Werkzeuge auf Anfrage

Herstellung nach Werkzeug- oder Werkstückzeichnung.

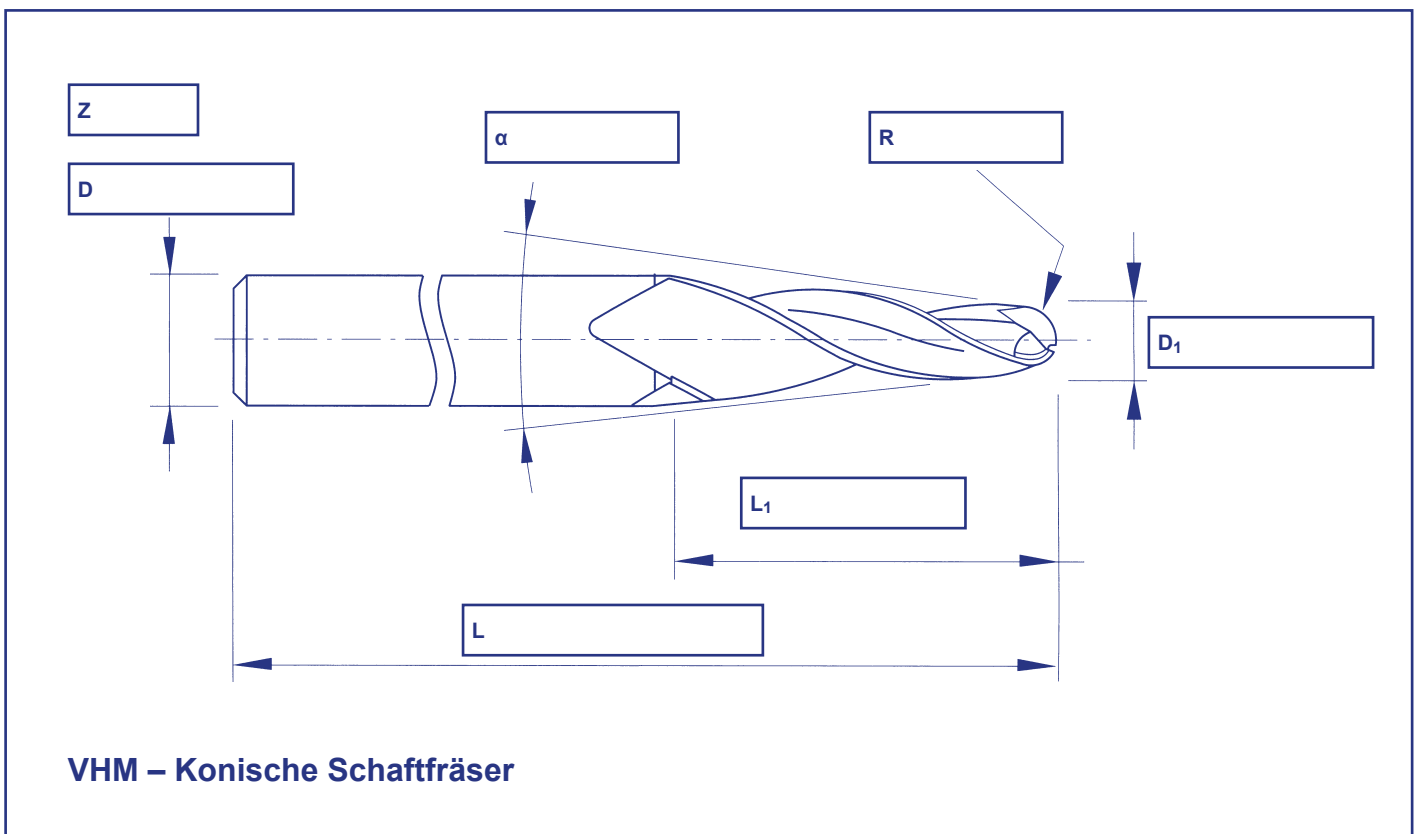
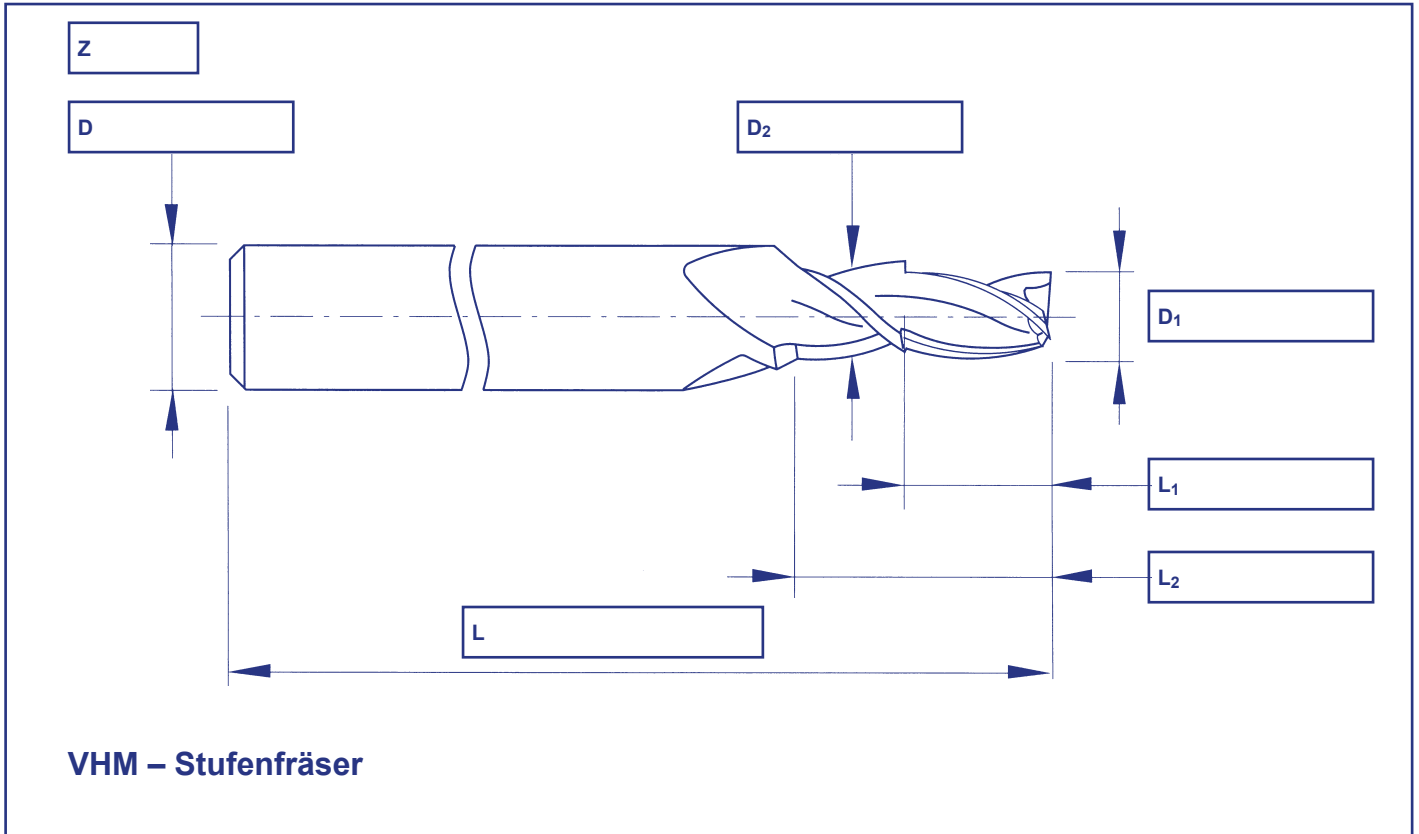

# Werkzeuge auf Anfrage

Herstellung nach Werkzeug- oder Werkstückzeichnung.

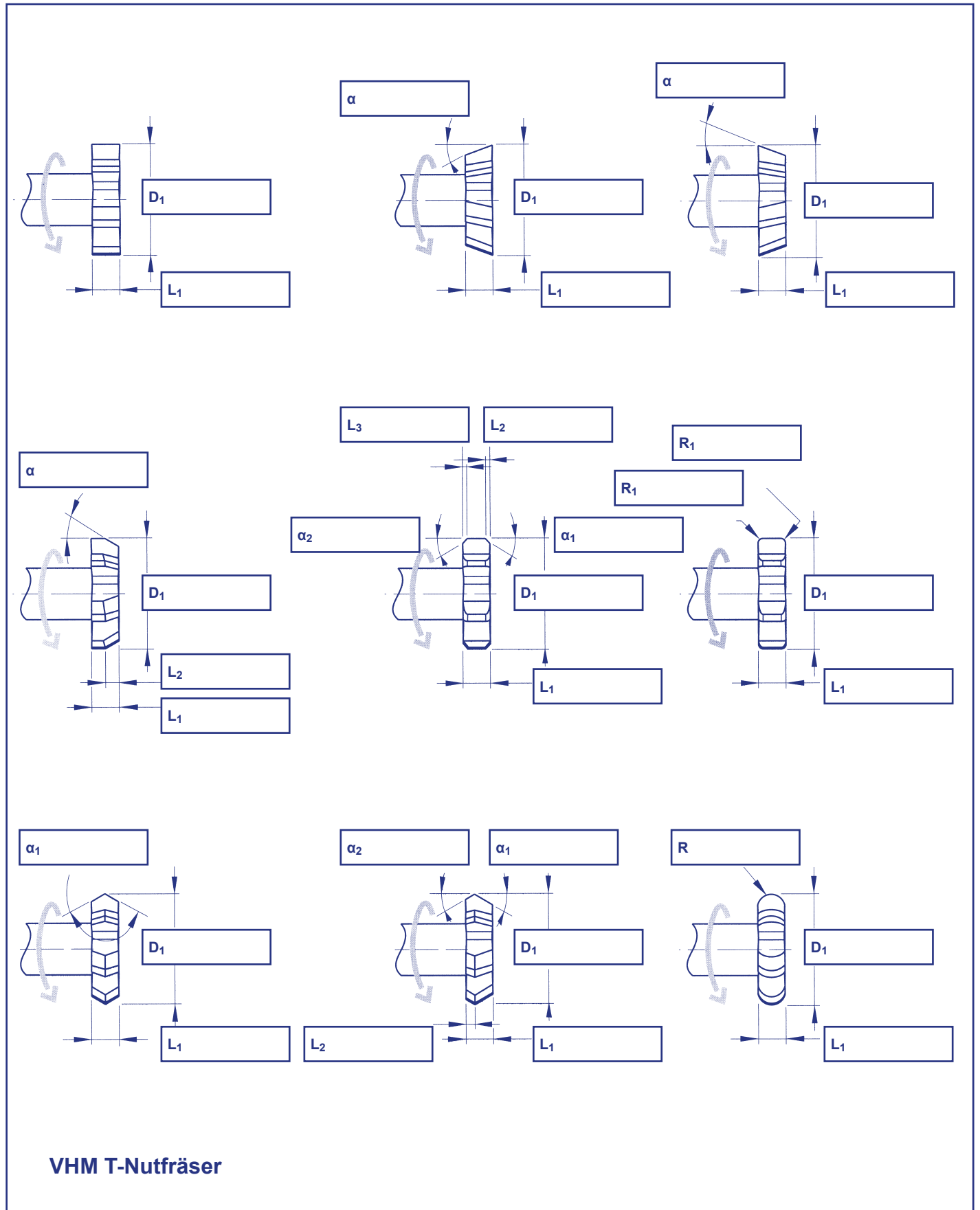

Kerger Tools Werkzeugtechnik  
Wolfsölder Weg 5  
71563 Affalterbach  
Tel.: 07144/83 13-51  
Fax: 07144/83 13-52  
[www.kerger-tools.de](http://www.kerger-tools.de)  
[info@kerger-tools.de](mailto:info@kerger-tools.de)